

All caps 400v unless otherwise marked.
 All resistors 1/2W unless otherwise marked.
 D1, D2: 1N4007

Octal Fatness

David Jones © 2003
 (Schematic: Doug Hammond © 2004)

Power Transformer: Stock Electar Tube 10: 325-0-325
 Output Transformer: Antique Electronics PT-31

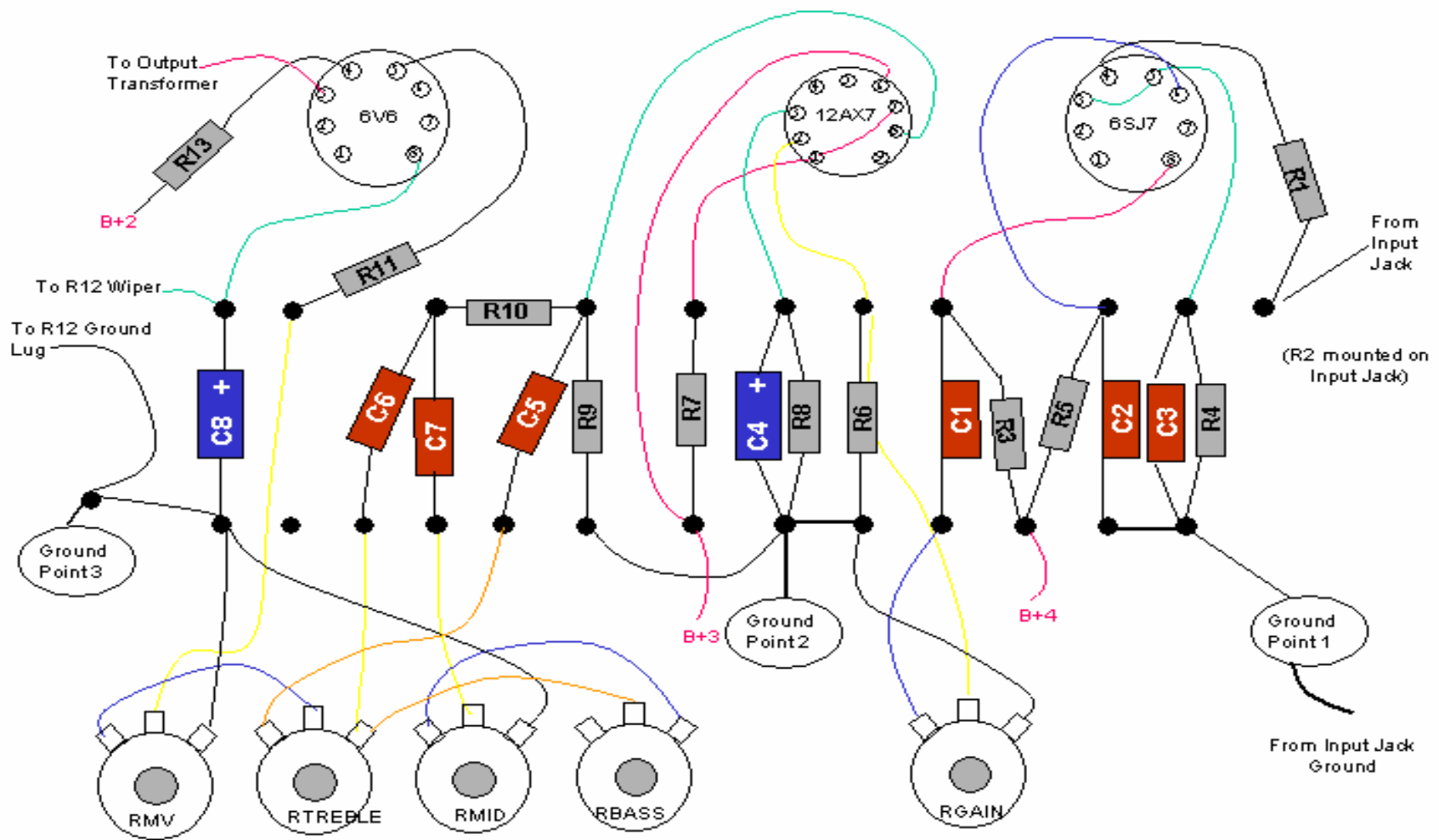

Octal Fatness Preamp and Power Amp Layout

Doug Hammond © 2004

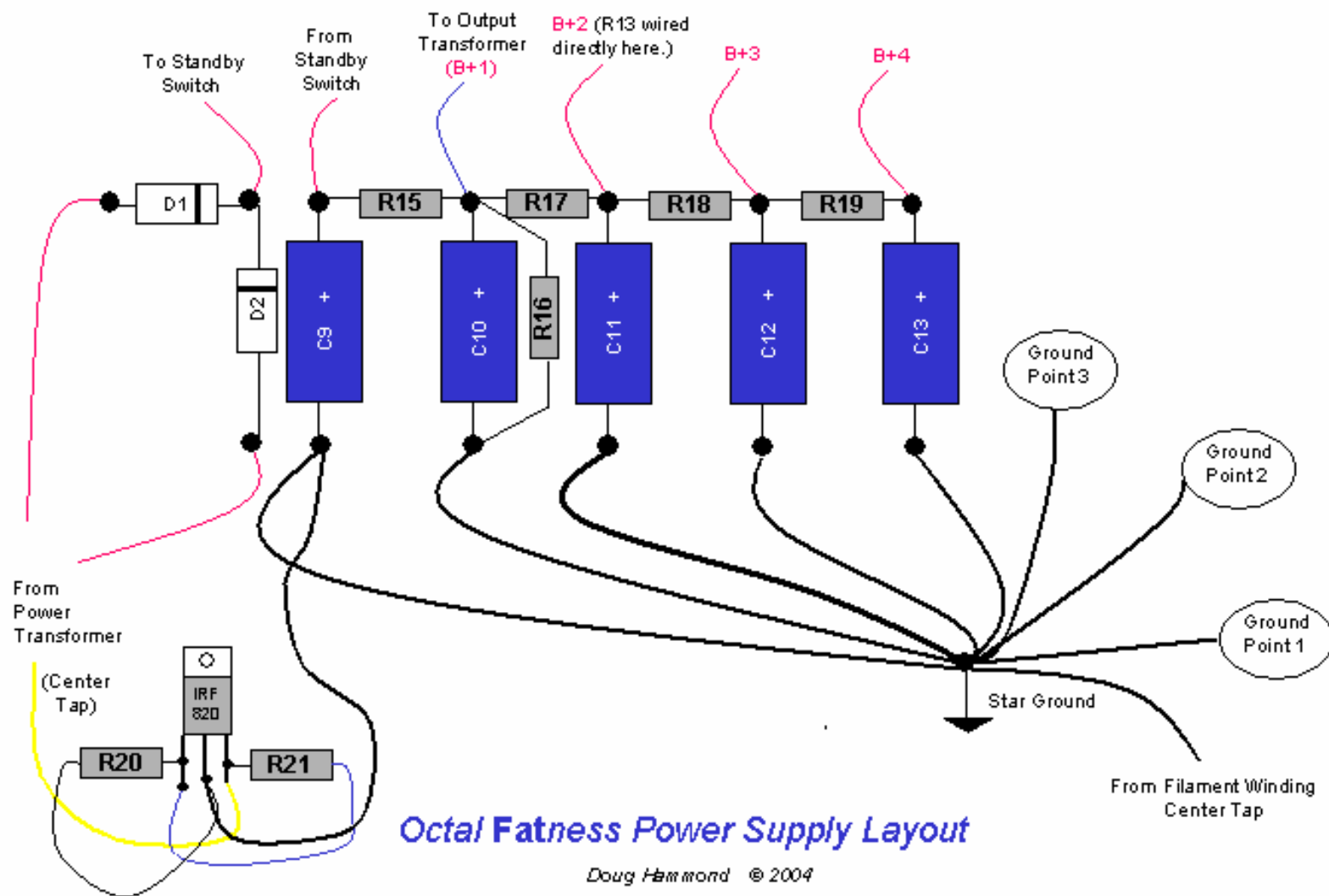

To Standby Switch

From Standby Switch

To Output Transformer (B+1)

B+2 (R13 wired directly here.)

B+3

B+4

Ground Point3

Ground Point2

Ground Point1

Star Ground

From Filament Winding Center Tap

From Power Transformer

(Center Tap)

IRF 820

R20

R21

Octal Fatness Power Supply Layout

Doug Hammond © 2004

